

FEATURES

- > High current carry in a small package
- > Tungsten contacts improve load switching capability**
- > Mounting options in any axis
- > Threaded HV terminals provide easy and secure connection



PRODUCT SPECIFICATIONS

Contact & Relay Ratings	Units	G50
Contact Form		C
Contact Arrangement		SPDT
Contact Material (moveable/stationary)		molybdenum /tungsten
Dielectric		Vacuum
Voltage, Test Max., Contacts & to Base (15 µA Leakage Max.) dc or 60Hz	kV Peak	30
Voltage, Operating Max., Contacts & to Base (15 µA Leakage Max.) dc or 60 Hz	kV Peak	25
Current, Load Switching		Contact factory**
Current, Continuous Carry Max	Amps	110
Coil Hi-Pot (V RMS, 60 Hz)	V	500
Capacitance		
Across Open Contacts	pF	5
Contacts to Ground	pF	5
Resistance, Contact Max @ 1A, 28 Vdc	ohms	0.005
Operate Time	ms	100
Release Time	ms	15
Life, Mechanical	cycles	1 million
Weight, Nominal	g (oz)	1000 (35)
Vibration, Operating, Sine (55-500 Hz Peak)	G's	10
Shock, Operating, 1/2 Sine11ms (Peak)	G's	30
Temperature Ambient Operating	°C	-55 to +125
Maximum Terminal Temperature	°C	200

COIL RATINGS

Nominal, Volts dc	12	26.5
Pick-up, Volts dc, Max.	8	16
Drop-Out, Volts dc	.5 - 5	1 - 10
Coil Resistance (Ohms ±10%)	15	60

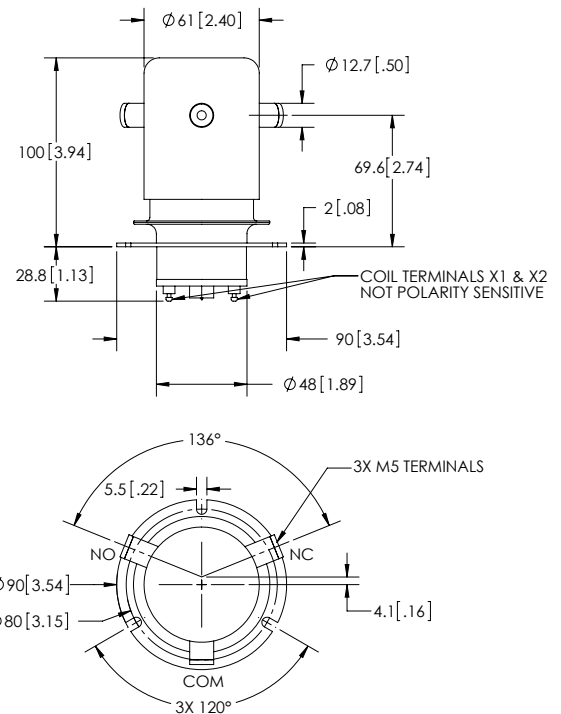

PART NUMBER SYSTEM

G50	W	F	
High Voltage/Power Terminal Connections	W = Screw		
Mounting		F = Flange	
Coil Voltage*			Blank = 26.5 Vdc -12Vdc = 12 Vdc

* Order the relay with the coil voltage in the part number as shown above. The coil voltage will appear on the coil plate near the coil terminals rather than in the P/N on the relay.

** Consult factory for load switching applications.