

Sendyne SFP203MOD Precision Current Measurement Module

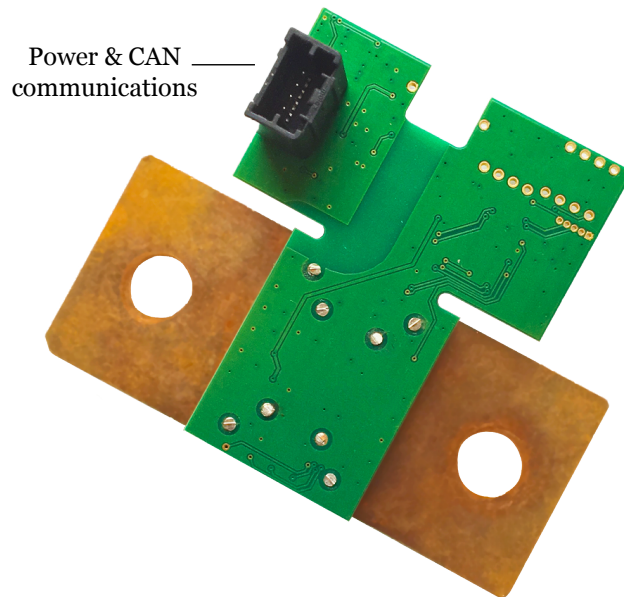

Description

The Sendyne SFP203MOD is a shunt-based, automotive grade precision module capable of measuring currents from mA to 500 A continuous. The module incorporates Sendyne's SFP200 IC and an 18 $\mu\Omega$ shunt and achieves an accuracy of better than $\pm 1.0\%$ (typically $\pm 0.5\%$) over the entire operating temperature range of $-40\text{ }^{\circ}\text{C}$ to $+125\text{ }^{\circ}\text{C}$.

The module simultaneously measures bi-directional DC current through the shunt temperature, as well as provides separate charge, discharge and total Coulomb output.

The module provides automatic compensation for resistance dependence of the shunt on temperature.

Communications are achieved via an isolated CAN 2.0B interface (500 kbit/s).

Applications

- Battery monitoring for automotive applications
- Grid energy storage
- Home energy storage

Operating Specifications

Parameter	Value
Shunt value	18 $\mu\Omega$
Power supply	+4.5 ~ +5.5 V
Interface	CAN 2.0B isolated, 120 Ω terminated
Current measurement range	$\pm 500\text{ A}$ continuous / $\pm 1000\text{ A}$ (5 s), $< \pm 1.0\%$ error
Rating	Automotive
Power consumption	$< 350\text{ mW}$

Technical Specifications

Electrical Specifications

Parameter	Min	Typ	Max	Units	Conditions/Comments
Power and General					
Shunt & electronics operating temperature range	-40		+125	°C	
Operating temperature range for connectors	-40		+105	°C	
Supply Current			50	mA	
Start-up time		0.5	0.75	s	After initial application of power and power supply stabilization
Current Measurement					
Total Shunt Resistance	16	18	20	μΩ	
Nominal Full-scale current		±500		A	Continuous rating in still air at room temperature of 23 °C with module connected to 18" (457 mm) 1/0 AWG cable on each side
Peak Full-scale current		±1250		A	Maximum current value that is measured without clipping; less than 5 s duration, the same conditions as above
Current offset error*	-50	<±20	+50	mA	Uncalibrated performance, applies over the full operating temperature range
Current noise error*		<25	50	mA _{RMS}	1 Hz reporting rate
Current value error*	-0.25		+0.25	%	Room temperature, test current ±20 A or higher
	-0.5		+0.5	%	0 °C to +50 °C, test current as above
	-1		+1	%	-40 °C to +125 °C, test current as above
		±1		%	End of life, test current as above
Current measurement resolution		<100		μA	Minimum discernible current change; corresponds to one count of Analog to Digital Converter (ADC), 1 Hz current report rate

* The combined Total Current Error is the ±sum of Current offset error, Current noise error, and [Current value error] x [measured value]. For currents over 100 A the Current offset error and the Current noise error could be omitted from the calculation since they will typically contribute less than 0.05 % to the error.

Electrical Specifications

Parameter	Min	Typ	Max	Units	Conditions/Comments
Charge measurement resolution		<1		μC	Minimum discernible amount of charge change, 100 Hz report rate

Temperature Measurement (For shunt temperature measurement)

Absolute temperature measurement error	-5	±0.5	+5	°C	Built-in temperature sensor for shunt temperature measurements
Temperature measurement resolution			10	m°C	Practical temperature measurement granularity

Isolation

Test voltage		3		kV _{DC}	CAN interface to SHUNT. 1 min duration
--------------	--	---	--	------------------	---

Communication

Interface	Spec	Speed	Termination	Number of units in the same CAN branch
CAN	2.0B	500 kb/s	120 Ω	1

Connectors

Interface	Manuf	Positions	Part number	Description
CAN & power on board	Molex	4	347920040	4 pos. header, Shrouded connector (2.00 mm), Through hole tin
Can & power mating con.	Molex	4	347910040	Use appropriate crimp contacts (available for AWG 22, 24 and 26)

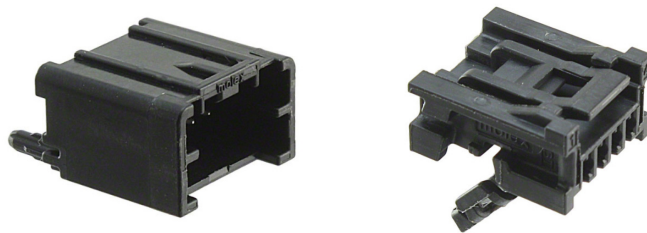

CAN and Power header & mating connectors

CAN Connector Pinout Description

Pin Number	Description
Pin 1	GND
Pin 2	CAN HIGH
Pin 3	CAN LOW
Pin 4	VCC

The SFP203MOD uses Molex connectors, part number 347920040.
 For more details please see the Molex datasheets: www.molex.com/pdm_docs/sd/347920040_sd.pdf

Measured performance data

Current error over temperature range of -40 °C to +125 °C

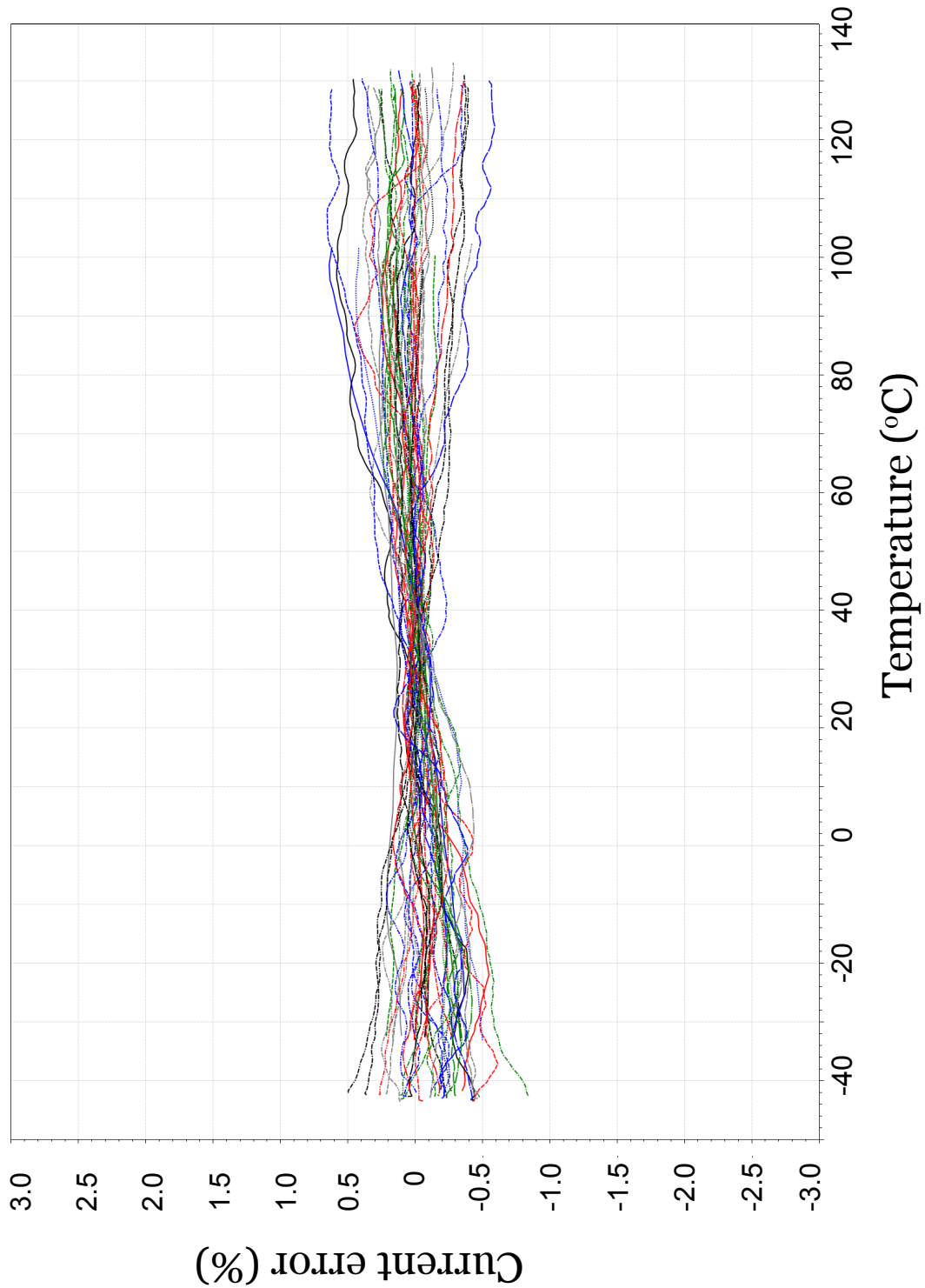

Mechanicals

SFP203MOD general dimensions [mm]

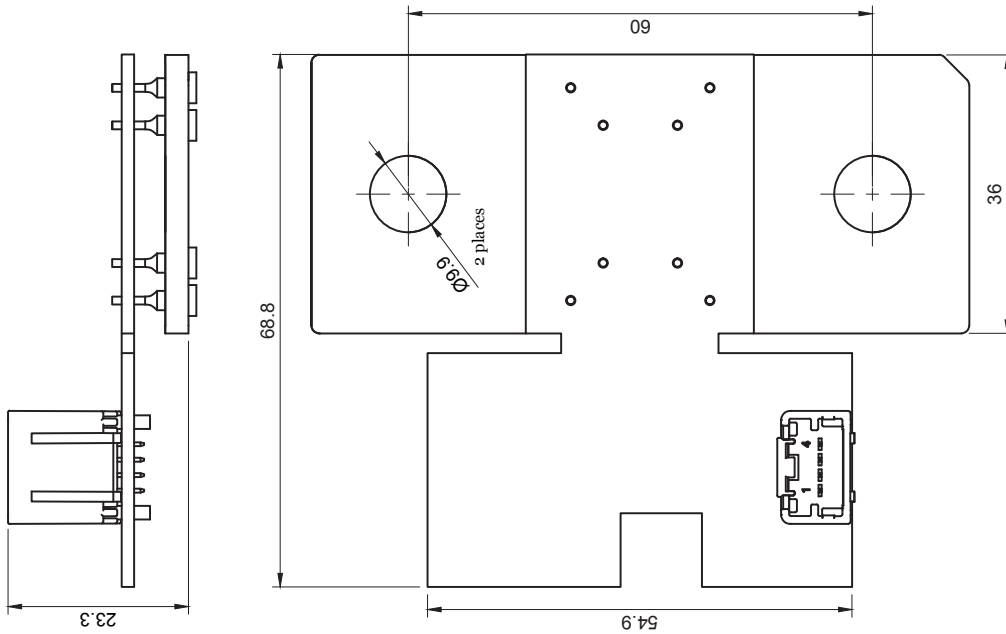
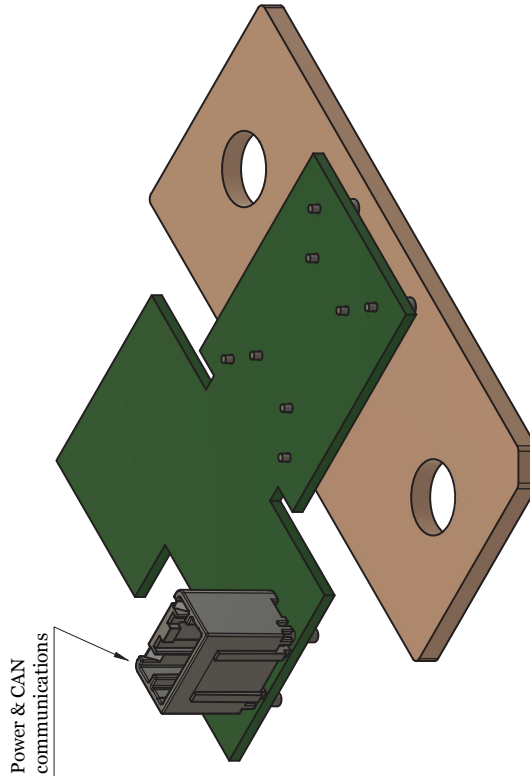
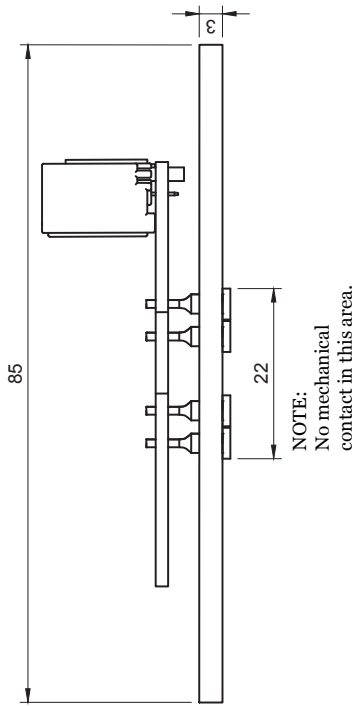

Mechanicals

SFP203MOD shunt contact points [mm]

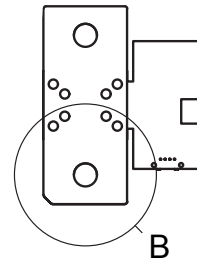
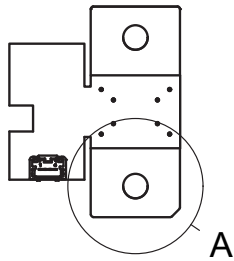

A (2:1)

B (2:1)

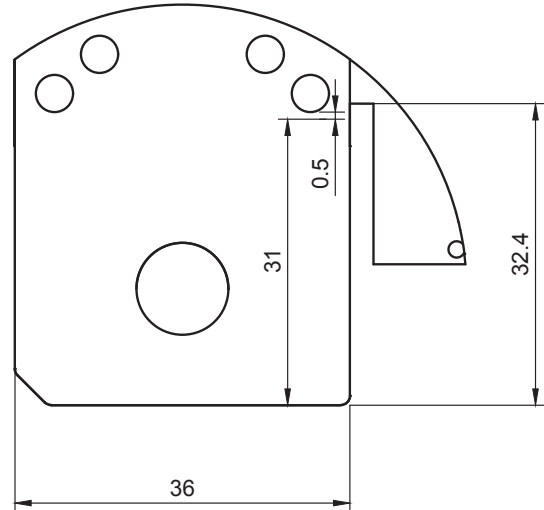
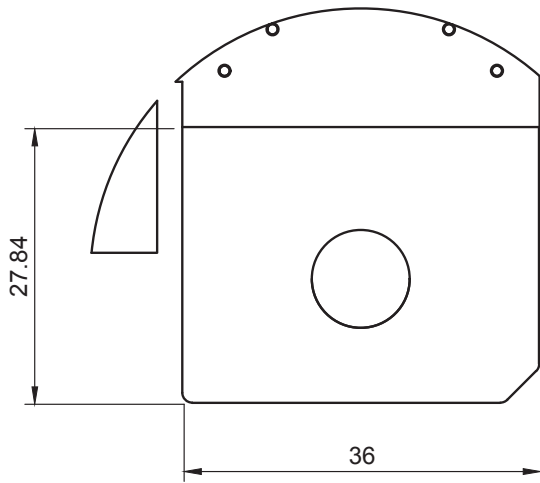

SFP203MOD block diagram

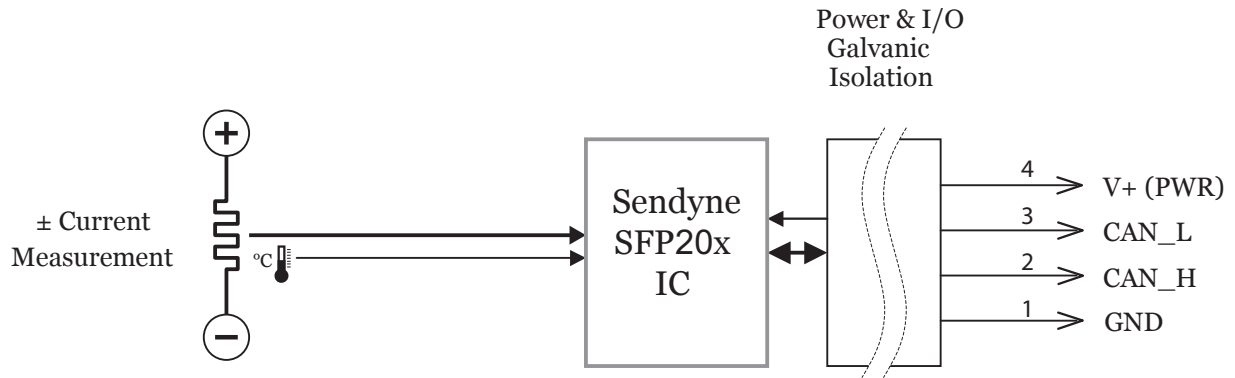

Ordering Information

Part Number	Description
SFP203CA-MOD	SFP203MOD Module
SFP203KIT	SFP203MOD module, CAN to USB protocol converter for PC communication, Windows software and cable

Revision History

Revision Table

Revision Number	Date	Comments
0.1	2/20/2017	Preliminary; Initial release

Information contained in this publication regarding device applications and the like is provided only for your convenience and may be superseded by updates.

SENDYNE MAKES NO REPRESENTATIONS OR WARRANTIES OF ANY KIND WHETHER EXPRESSED OR IMPLIED, WRITTEN OR ORAL, STATUTORY OR OTHERWISE, RELATED TO THE INFORMATION, INCLUDING BUT NOT LIMITED TO ITS CONDITION, QUALITY, PERFORMANCE, MERCHANTABILITY OR FITNESS FOR PURPOSE. Sendyne disclaims all liability arising from this information and its use. Use of Sendyne devices in life support and/or safety applications is entirely at the buyer's risk, and the buyer agrees to defend, indemnify and hold harmless Sendyne from any and all damages, claims, suits, or expenses resulting from such use. No licenses are conveyed, implicitly or otherwise, under any Sendyne intellectual property rights.

Patents

US Pat. 8,264,216
US Pat. 8,289,030
US Pat. 9,052,343
Other patents pending

Trademarks

The Sendyne name and logo are registered trademarks of Sendyne Corp.

All other trademarks mentioned herein are properties of their respective owners.

© 2016 Sendyne Corp.

All Rights Reserved.

1234567890 1234567890

