

- **2-Synchro/Resolver to Digital Converters**
  - Selectable Resolution at 10, 12, 14 or 16 bit
  - Interface for Either 3-wire Synchro or 4-wire Resolver
  - 11.8Vrms Input Voltage
  - Input Frequencies of 400Hz to 3kHz
  - AC Voltage Source/Frequency Reference Software Configurable for Frequencies of 400Hz or 1200Hz
- **A/D Converter**
  - 16-bit A/D Conversions at 100 kSPS
  - 8 Single-Ended or 4 Differential Software Selectable Analog Inputs
  - $\pm 10V$  Analog Input Range
  - 2 AC Input Interfaces
- **D/A Converter**
  - 12-bit resolution
  - 4 Analog Outputs: 2 Voltage Mode, 2 Configurable as  $\pm 10$  Analog Voltage Mode or 0 to 20 mA Current Mode
- **Multiple Discrete Interfaces**
  - 16 TTL or 8 Differential I/O
  - 4 General Purpose, TTL I/O
  - 4 Low-side Solenoid Drivers
  - 2 High-side Drivers
- **PCI 2.1 Interface Compliant, 32 bit @ 33 MHz PCI Bus Interface**
- **Air-Cooled Version Compliant with IEEE 1386-2001 Specification**
- **Conduction-Cooled Version Compliant with ANSI/VITA20-2001**
- **Three Ruggedization Levels**
- **VxWorks<sup>®</sup> Drivers**
- **BIT (Built-in-Test) Available for complete Functional Testability**

## Servo I/O PMC

The M410 Servo I/O PMC board is designed to provide three-wire Synchro-to-Digital (or four wire Resolver-to-Digital) conversion at 14-bit resolution (minimum) on a cost effective and small industrial PMC form factor. An on-board, synthesized AC-voltage source and frequency generator provide built-in-test (BIT) capability for the Synchro-to-Digital (S/D) converters.

To complement the S/D converters, general-purpose digital and analog I/O are also designed to provide a PMC solution that is suitable for a configurable servo-control-loop application.

All I/O can be sampled and stored in on-board, memory-mapped SRAM for further inspection and processing by the host processor. All I/O is BIT capable.

Implemented in an Actel FPGA, the M410 supports a high performance PCI interface that is fully compliant with PCI specification, revision 2.1.

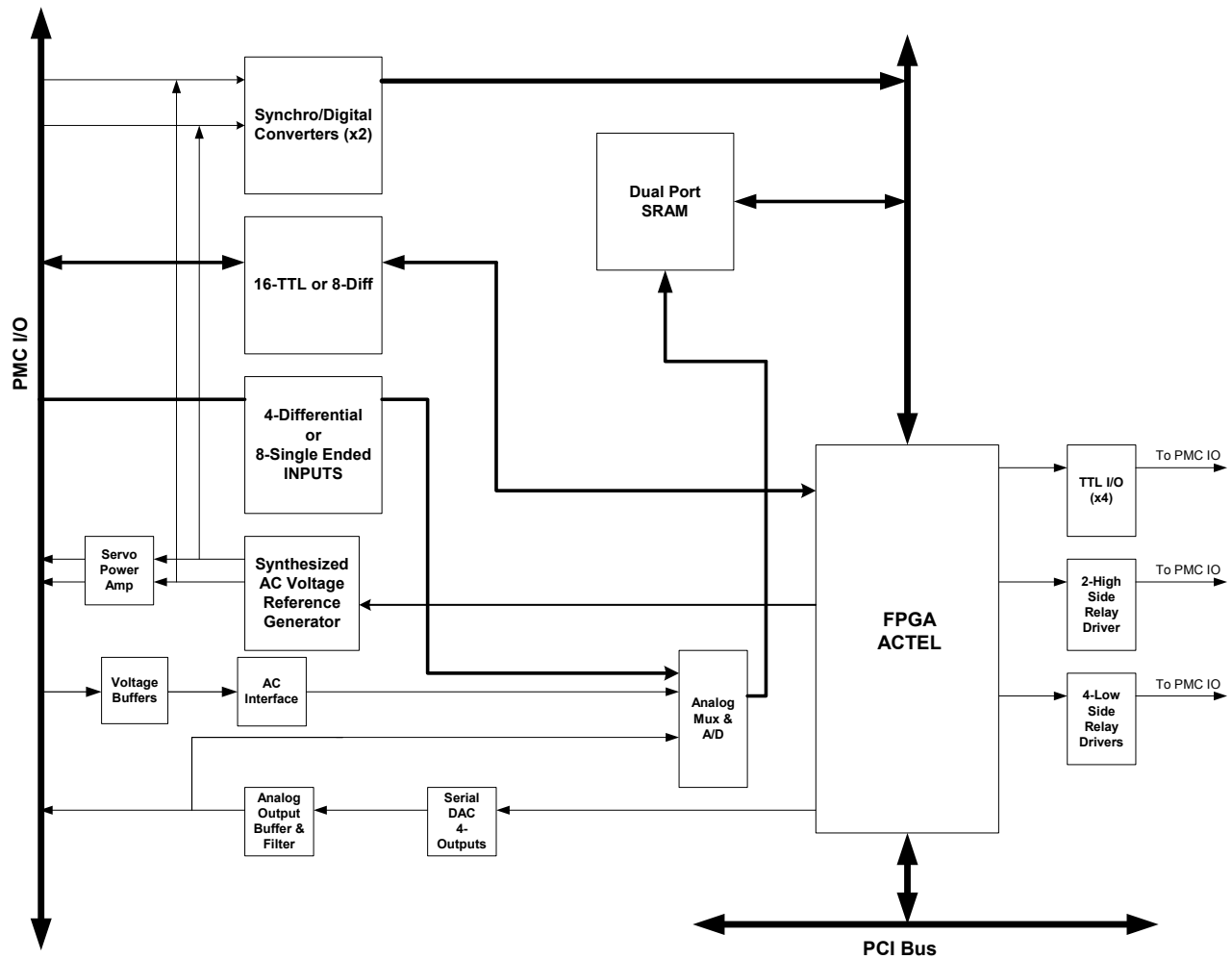

**M410 Block Diagram**



## Features

### Architecture

The M410 architecture provides various interfaces to support control systems applications. It has 2 Synchro or Resolver inputs with 2 multiplying DACs for BIT stimulate, 8 single-ended or 4 differential analog inputs, 4 analog outputs, 16 TTL or 8 differential digital I/Os, 2 –High-side and 4 –Low-side drivers, 4 TTL I/Os, 2 AC voltage presence input monitors, 2 buffered analog input, and a 400 or 1200 Hz frequency generator.

### Synchro/Resolver Inputs

Each Synchro/Resolver interface employs Data Devices Corporation's RDC-19222 chip. The RDC-19222 converts the phase/amplitude from a Synchro or Resolver to a digital angle and velocity. The resolution of the RDC is factory set to 10, 12, 14, or 16 bits. The input interface is direct connection and supports either 3-wire or 4-wire with voltage scaling resistor settable at factory. Two multiplying DACs are used to simulate Sine and Cosine input to RDC-19222 during BIT.

### Differential or Single-Ended Analog Inputs

The M410 analog inputs consist of 8 –single-ended inputs with unity gain that can be converted to 4 differential analog inputs. The analog signal is digitized by the Linear Technology's LTC1605 16-bit 100 kSPS A/D converter. The selection of differential or single-ended mode is commanded through software. The analog input voltage range is  $\pm 10$  Volts. All analog inputs have low pass anti-aliasing filters.

### Analog Outputs

The M410 provides 4 analog outputs using Analog Devices' AD7398 Quad 12-bit DAC. Two of these outputs are voltage mode and are factory configurable for 0 to +10 Volts or –10 to +10 Volts outputs. The other two outputs are factory configurable for use as either current mode with 0 to 20 milliAmps outputs or voltage mode with either 0 to +10 Volts or –10 to +10 Volts outputs. All analog outputs have low pass filters to smooth out the conversion steps.

### Digital I/Os

For digital/discrete interfaces, the M410 provides multiple discretely software configurable between 16-bit TTL I/Os or 8-bit differential (RS-485 or RS-422 compatible) I/Os, 4-bit TTL-only I/Os, 2-bit for High-side drivers, and 4-bit for Low-side drivers.

The TTL or differential I/Os can be software configured as either input or output ports. Each bit of the 4-bit TTL only I/Os can be software configured as either input or output. The High-side drivers support 28V input with 150 m $\Omega$  ON resistance per driver. The Low-side drivers share common return with 500 m $\Omega$  ON resistance per driver. The Low-side's return can be factory set to board digital Ground or external return.

### PCI Bus Interface

The M410 incorporates a high performance PCI to Local Bus Bridge supporting 32-bit operation at 33 MHz and fully compliant with the PCI Rev. 2.1 specification.

## Software

### Test and Diagnostics Features

- Full Functional testability using internal BIT stimulus, redundant input paths, and analog output loopbacks.
- BIT software provided for loading on the host processor platform

### Software Drivers

The M410 PMC is delivered with a complete set of VxWorks<sup>®</sup> drivers and BIT. These should be integrated into the carrier (host) VxWorks<sup>®</sup> platform.

## Mechanical Features

The M410 PMC is available in two mechanical formats:

- Air-cooled per IEEE 1386-2001 for installation on top commercial and rugged air-cooled carrier boards.



- Conduction cooled per ANSI/VITA20-2001 for installation on top IEEE 1101.2 conduction-cooled carrier boards.

High power components are cooled by an aluminum heatsink.

#### Dimensions

- Air-cooled: per IEEE 1386-2001
- Conduction cooled: per ANSI/VITA 20-2001

#### Power Requirements

Total power consumption (maximum): 5W

+5V	(± 5%)	0.55A
+12V	(± 10%)	0.073A
-12V	(± 10%)	0.073A

#### Environmental Features

Please, refer to the Aitech ruggedization datasheet

## Ordering Information for the M410

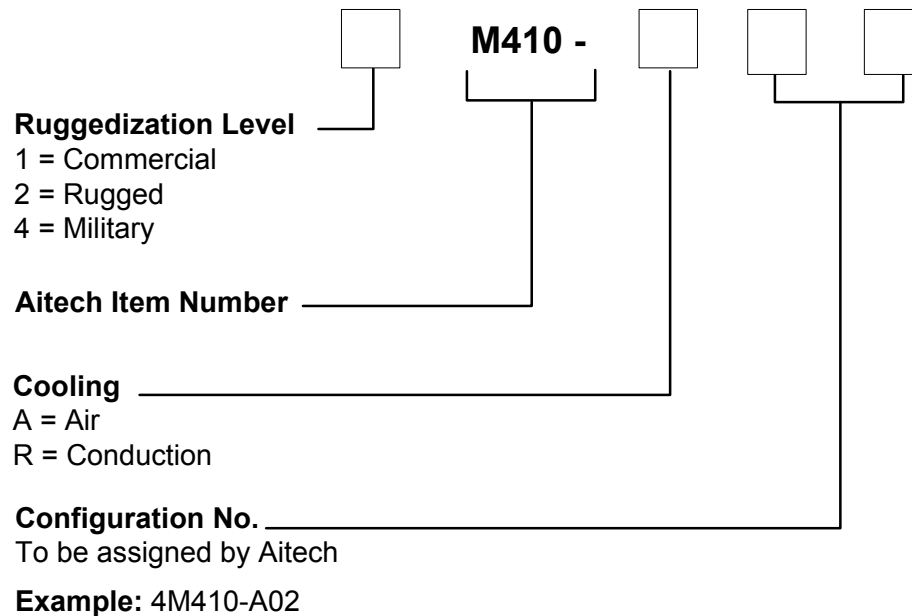

For more information about the M410 or any Aitech product, please contact Aitech Defense Systems sales department at (888) Aitech-8 (248-3248).

Names, products, and/or services mentioned are trademarks or registered trademarks of their respective holders. All information contained herein is subject to change without notice.

M410T0305R12